



THYRISTOR

DESCRIPTION

The UTC **BT152** is a thyristor, it uses UTC's advanced technology to provide customers with high bidirectional blocking voltage capability and high thermal cycling performance, etc.

The UTC **BT152** is suitable for motor control, industrial, static switching, heating and domestic lighting, etc.

FEATURES

- * High bidirectional blocking voltage capability
- * High thermal cycling performance

SYMBOL

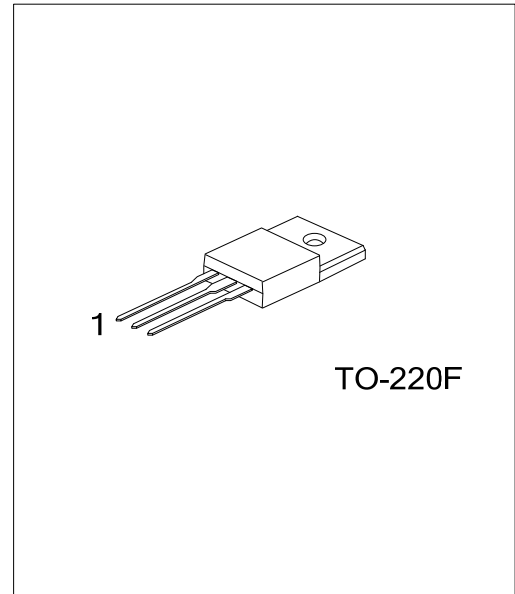
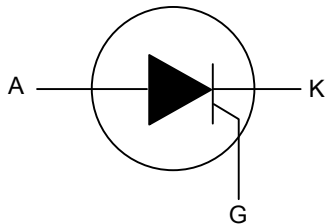

ORDERING INFORMATION

Ordering Number		Package	Pin Assignment			Packing
Lead Free	Halogen Free		1	2	3	
BT152L-x-TF3-T	BT152G-x-TF3-T	TO-220F	K	A	G	Tube

Note: Pin Assignment: K: Cathode A: Anode G: Gate

<p>BT152L-x-TF3-T</p>	<p>(1)Packing Type</p> <p>(2)Package Type</p> <p>(3)Peak Voltage</p> <p>(4)Lead Free</p>	<p>(1) T: Tube</p> <p>(2) TF3: TO-220F</p> <p>(3) 4: 450V, 6: 650V, 8: 800V</p> <p>(3) L: Lead Free, G: Halogen Free</p>
-----------------------	--	--

■ ABSOLUTE MAXIMUM RATINGS

PARAMETER		SYMBOL	RATINGS	UNIT
Repetitive Peak Off-State Voltages	BT152-4	V_{DRM}, V_{RRM}	450	V
	BT152-6		650	V
	BT152-8		800	V
Average On-State Current	Half Sine Wave, $T_{MB} \leq 103^\circ\text{C}$	$I_{T(AV)}$	13	A
RMS On-State Current	All Conduction Angles	$I_{T(RMS)}$	20	A
Non Repetitive Surge Peak On-State Current (Half Sine Wave; $T_J=25^\circ\text{C}$ Prior to Surge)	$t=10\text{ms}$	I_{TSM}	200	A
	$t=8.3\text{ms}$		220	A
I^2t Value for Fusing	$t=10\text{ms}$	I^2t	200	A^2s
Repetitive Rate of Rise of On-State Current After Triggering	$I_{TM}=50\text{A}, I_G=0.2\text{A},$ $dI_G/dt=0.2\text{A}/\mu\text{s}$	dI_T/dt	200	$\text{A}/\mu\text{s}$
Peak Gate Current		I_{GM}	5	A
Peak Gate Voltage		V_{GM}	5	V
Peak Reverse Gate Voltage		V_{RGM}	5	V
Peak Gate Power		P_{GM}	20	W
Average Gate Power Dissipation	Over Any 20ms Period	$P_{G(AV)}$	0.5	W
Storage Junction Temperature		T_{STG}	-40~+150	$^\circ\text{C}$
Operating Junction Temperature		T_J	125	$^\circ\text{C}$

Note: Absolute maximum ratings are those values beyond which the device could be permanently damaged. Absolute maximum ratings are stress ratings only and functional device operation is not implied.

■ THERMAL RESISTANCES

PARAMETER		SYMBOL	MIN	TYP	MAX	UNIT
Junction to Ambient	In Free Air	θ_{JA}		60		K/W
Thermal Resistance Junction to Mounting Base		θ_{JMB}			1.1	K/W

■ STATIC CHARACTERISTICS ($T_J=25^\circ\text{C}$ unless otherwise stated)

PARAMETER	SYMBOL	TEST CONDITIONS	MIN	TYP	MAX	UNIT
Gate Trigger Current	I_{GT}	$V_D=12\text{V}, I_T=0.1\text{A}$		3	32	mA
Latching Current	I_L	$V_D=12\text{V}, I_{GT}=0.1\text{A}$		25	80	mA
Holding Current	I_H	$V_D=12\text{V}, I_{GT}=0.1\text{A}$		15	60	mA
On-State Voltage	V_T	$I_T=40\text{A}$		1.4	1.75	V
Gate Trigger Voltage	V_{GT}	$V_D=12\text{V}, I_T=0.1\text{A}$		0.6	1.5	V
		$V_D=V_{DRM(max)}, I_T=0.1\text{A}, T_J=125^\circ\text{C}$	0.25	0.4		V
Off-State Leakage Current	I_D	$V_D=V_{DRM(max)}, V_R=V_{RRM(max)},$ $T_J=125^\circ\text{C}$		0.2	1.0	mA
	I_R	$T_J=125^\circ\text{C}$		0.2	1.0	mA

■ DYNAMIC CHARACTERISTICS ($T_J=25^\circ\text{C}$ unless otherwise stated)

PARAMETER	SYMBOL	TEST CONDITIONS	MIN	TYP	MAX	UNIT
Critical Rate of Rise of Off-State Voltage	dV_D/dt	$V_{DM}=67\%V_{DRM(max)}, T_J=125^\circ\text{C},$ Exponential Waveform Gate Open Circuit	200	300		$\text{V}/\mu\text{s}$
Gate Controlled Turn-On Time	t_{GT}	$V_D=V_{DRM(max)}, I_G=0.1\text{A},$ $dI_G/dt=5\text{A}/\mu\text{s}, I_5$ $T_M=40\text{A}$		2		μs
Circuit Commutated Turn-Off Time	t_Q	$I_{TM}=50\text{A}, V_R=25\text{V}, dI_{TM}/dt=30\text{A}/\mu\text{s},$ $dV_D/dt=50\text{V}/\mu\text{s}, R_{GK}=100\Omega$		70		μs

UTC assumes no responsibility for equipment failures that result from using products at values that exceed, even momentarily, rated values (such as maximum ratings, operating condition ranges, or other parameters) listed in products specifications of any and all UTC products described or contained herein. UTC products are not designed for use in life support appliances, devices or systems where malfunction of these products can be reasonably expected to result in personal injury. Reproduction in whole or in part is prohibited without the prior written consent of the copyright owner. The information presented in this document does not form part of any quotation or contract, is believed to be accurate and reliable and may be changed without notice.